

SYNTHESIZING SELF-SYNCHRONIZING CHAOTIC SYSTEMS

Kevin M. Cuomo

Research Laboratory of Electronics, Massachusetts Institute of Technology, Cambridge, MA 02139
(Received Date)

A systematic approach is developed for synthesizing N -dimensional dissipative chaotic systems which possess the self-synchronization property. The ability to synthesize new chaotic systems further enhances the usefulness of synchronized chaotic systems for communications.

1. INTRODUCTION

It is well known that a certain class of chaotic systems possess a self-synchronization property [Pecora & Carroll, 1990 & 1991; Carroll & Pecora, 1991]. Specifically, two identical chaotic systems may synchronize when the second system is driven by the first. Pecora and Carroll [1990 & 1991] have shown numerically that synchronization occurs if all of the Lyapunov exponents for the driven system are negative. Later, He and Vaidya [1992] developed the necessary and sufficient conditions for synchronization using the notion of asymptotic stability. As discussed in [Oppenheim *et al.*, 1992; Cuomo & Oppenheim, 1992 & 1993; Parlitz *et al.*, 1992; Kocarev *et al.*, 1992], the combination of synchronization and unpredictability from purely deterministic systems leads to some interesting communication applications.

A potential drawback for utilizing synchronized chaotic systems in communications is that the analysis and synthesis of chaotic systems is not well understood due to the highly nonlinear nature of these systems. In fact, only a few chaotic systems which possess the self-synchronization property are currently known. In He & Vaidya [1992], it was demonstrated that it is possible to use Lyapunov functions to create a five-dimensional chaotic system by augmenting the Lorenz system with additional states. However, the approach involves considerable trial and error.

In this paper, we utilize Lyapunov functions to develop a *systematic* approach for synthesizing N -dimensional dissipative chaotic systems which possess the self-synchronization property. The ability to analyze and synthesize new chaotic systems further enhances the usefulness of synchronized chaotic systems for communications. Our main theoretical results include the development of self-synchronization and global stability conditions for a certain class of chaotic systems. We also suggest a numerical procedure for studying the stability of the fixed points for this class of systems. Numerical

examples illustrate the results.

2. THEORY

In the development of the synthesis approach, we will limit consideration to nonlinear systems which are representable by a set of first-order ordinary differential equations having a quadratic vector field defined on R^N . While this limitation makes the problem more amenable to analysis, it also has the practical advantage of restricting the class of nonlinear systems to those which are relatively easy to implement. Specifically, a quadratic term in the vector field can be realized using a single analog multiplier, whereas a cubic or higher-order term would require additional components.

A general nonlinear system with a quadratic vector field is given by

$$\dot{\mathbf{x}} = A\mathbf{x} + (\mathbf{x}^T Q_1 \mathbf{x}, \dots, \mathbf{x}^T Q_N \mathbf{x}) \quad (1)$$

The vector \mathbf{x} denotes the N states (x_1, \dots, x_N) , the A matrix is $N \times N$, and the Q_i , $i = 1, \dots, N$, are symmetric $N \times N$ matrices. In the communication scenario illustrated in Fig. 1, Eq. (1) can be interpreted as a transmitter or drive system which transmits the chaotic signal $x_1(t)$ over a communications channel to the synchronizing receiver(s). Because chaotic signals are typically broadband, noise-like, and difficult to predict, they can be used in various contexts to mask information-bearing waveforms. They can also be used as modulating waveforms in spread spectrum systems. The self-synchronization property provides the potential for coherent information transfer between the transmitter and receiver. For example, the ability to privately communicate speech waveforms between the transmitter and receiver was demonstrated in Cuomo & Oppenheim [1992 & 1993] using an analog circuit implementation of the Lorenz equations.

It is useful in our subsequent analysis to express

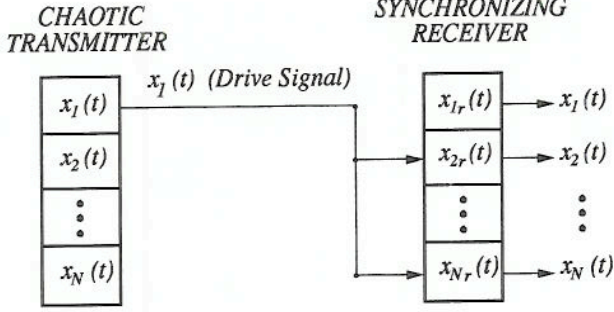

Figure 1: A Chaotic Communication System.

Eq. (1) in the form

$$\dot{\mathbf{x}} = A_0 \mathbf{x} + \mathbf{a}^0 x_1 + (\mathbf{x}^T Q_1 \mathbf{x}, \mathbf{x}^T Q_2 \mathbf{x}, \dots, \mathbf{x}^T Q'_N \mathbf{x}) + 2A_1 x_1 \mathbf{x} + \mathbf{s}^0 x_1^2. \quad (2)$$

This form results by decomposing the A matrix into $A = A_0 + \mathbf{a}^0 \mathbf{e}_1^T$, where

$$A_0 = \begin{bmatrix} a_{11} & a_{12} & \cdots & a_{1N} \\ 0 & a_{22} & \cdots & a_{2N} \\ \vdots & \vdots & \ddots & \vdots \\ 0 & a_{N2} & \cdots & a_{NN} \end{bmatrix},$$

$$\mathbf{a}^0 = \begin{bmatrix} 0 \\ a_{21} \\ \vdots \\ a_{N1} \end{bmatrix}, \quad \mathbf{e}_1 = \begin{bmatrix} 1 \\ 0 \\ \vdots \\ 0 \end{bmatrix}.$$

Also, the matrices Q_i , $i = 2, \dots, N$, have been decomposed into $Q_i = Q'_i + \mathbf{q}_i^0 \mathbf{e}_1^T + \mathbf{e}_1 \mathbf{q}_i^{0T} + \mathbf{e}_1 \mathbf{e}_1^T q_i$, where

$$Q'_i = \begin{bmatrix} 0 & 0 & \cdots & 0 \\ 0 & q_{22}^{(i)} & \cdots & q_{2N}^{(i)} \\ \vdots & \vdots & \ddots & \vdots \\ 0 & q_{N2}^{(i)} & \cdots & q_{NN}^{(i)} \end{bmatrix},$$

$$\mathbf{q}_i^0 = \begin{bmatrix} 0 \\ q_{21}^{(i)} \\ \vdots \\ q_{N1}^{(i)} \end{bmatrix}, \quad q_i = q_{11}^{(i)}.$$

For simplicity in notation, the vectors \mathbf{q}_i^0 , $i = 2, \dots, N$ are collected in the matrix $A_1 = [\mathbf{0}, \mathbf{q}_2^0, \dots, \mathbf{q}_N^0]^T$ and the scalars q_i , $i = 2, \dots, N$, are collected in the vector $\mathbf{s}^0 = (0, q_2, \dots, q_N)$.

Note that the transmitter equations (1) have a total of $N^2(N+1)/2$ free parameters corresponding to the nonlinear terms. If these parameters were selected at random, it is unlikely that a chaotic system which possesses the self-synchronization property would result. We now determine sufficient conditions on the algebraic structure of the transmitter

which guarantees that it possesses the global self-synchronization property.

2.1. Conditions for Global Self-Synchronization

As we show below, by requiring that a self-synchronizing receiver exists, many of the free parameters in the transmitter equations will vanish. Also, a significant analytical simplification is obtained by requiring the transmitter/receiver error dynamics to be linear.

Requirement 1 *The transmitter equations must allow for the existence of a single-input globally self-synchronizing receiver. Moreover, the error dynamics between the transmitter and receiver must be linear.*

It is beneficial from an implementation viewpoint if the receiver has the same algebraic structure as the transmitter. Thus, consider a receiver which is formed from the transmitter (2) by renaming variables $\mathbf{x} \rightarrow \mathbf{x}_r$. The resulting receiver is given by

$$\dot{\mathbf{x}}_r = A_0 \mathbf{x}_r + \mathbf{a}^0 x_1 + (\mathbf{x}_r^T Q_1 \mathbf{x}_r, \mathbf{x}_r^T Q_2 \mathbf{x}_r, \dots, \mathbf{x}_r^T Q'_N \mathbf{x}_r) + 2A_1 x_1 \mathbf{x}_r + \mathbf{s}^0 x_1^2 \quad (3)$$

Sufficient conditions for the synchronization of the transmitter (2) and receiver (3) can be determined by forming the error system. The error system is obtained by defining $\mathbf{e} = \mathbf{x} - \mathbf{x}_r$ and subtracting (3) from (2) to obtain

$$\dot{\mathbf{e}} = (A_0 + 2A_1 x_1) \mathbf{e} + \begin{bmatrix} \mathbf{x}^T Q_1 \mathbf{x} - \mathbf{x}_r^T Q_1 \mathbf{x}_r \\ \mathbf{x}^T Q_2 \mathbf{x} - \mathbf{x}_r^T Q_2 \mathbf{x}_r \\ \vdots \\ \mathbf{x}^T Q'_N \mathbf{x} - \mathbf{x}_r^T Q'_N \mathbf{x}_r \end{bmatrix}.$$

If we now make the substitution $\mathbf{x}_r = \mathbf{x} - \mathbf{e}$, we obtain

$$\dot{\mathbf{e}} = (A_0 + 2A_1 x_1) \mathbf{e} + \begin{bmatrix} \mathbf{x}^T (Q_1 + Q_1^T) \mathbf{e} - \mathbf{e}^T Q_1 \mathbf{e} \\ \mathbf{x}^T (Q'_2 + Q_2^T) \mathbf{e} - \mathbf{e}^T Q'_2 \mathbf{e} \\ \vdots \\ \mathbf{x}^T (Q'_N + Q_N^T) \mathbf{e} - \mathbf{e}^T Q'_N \mathbf{e} \end{bmatrix}. \quad (4)$$

Observe that for linear error dynamics, the matrices Q_1 and Q'_i , $i = 2, \dots, N$, must be skew-symmetric. Since these matrices are also symmetric by definition, they must be identically zero for linear error dynamics. Thus, a significant simplification in the analysis is obtained by requiring the transmitter/receiver error dynamics to be linear.

Under these requirements, Eq. (4) reduces to

$$\dot{\mathbf{e}} = (A_0 + 2A_1 x_1) \mathbf{e}. \quad (5)$$

Equation (5) is linear in \mathbf{e} , but has a time-dependent chaotic coefficient $x_1(t)$. A sufficient condition for this system to be globally asymptotically stable at the origin can be obtained by considering a Lyapunov function of the form

$$E(\mathbf{e}) = \frac{1}{2} \mathbf{e}^T R \mathbf{e} ,$$

where R is a symmetric $N \times N$ positive definite matrix. The time rate of change of $E(\mathbf{e})$ along trajectories is given by

$$\begin{aligned} \dot{E}(\mathbf{e}) &= \mathbf{e}^T \frac{(RA_0 + A_0^T R)}{2} \mathbf{e} + \\ & x_1 \mathbf{e}^T (RA_1 + A_1^T R) \mathbf{e} . \end{aligned}$$

Observe that \dot{E} is negative definite if the following two conditions are satisfied.

- $RA_1 = -A_1^T R$
- $(RA_0 + A_0^T R)$ is negative definite

Because the first row and column of A_1 is the zero vector, the first condition can be satisfied by choosing R to be a diagonal matrix of the form $R = \text{diag}(p, 1, \dots, 1)$, $p > 0$, and restricting A_1 to be skew-symmetric. This restriction results in a further reduction in the number of free parameters in the transmitter equations. The second condition can be satisfied by choosing a stable matrix A_0 such that $(RA_0 + A_0^T R)$ is negative definite.

2.2. Conditions for Global Stability

Requirement 1 reduces the transmitter equations to the form

$$\dot{\mathbf{x}} = A_0 \mathbf{x} + \mathbf{a}^0 x_1 + 2A_1 x_1 \mathbf{x} + \mathbf{s}^0 x_1^2 . \quad (6)$$

By requiring the transmitter to be globally stable, further constraints on the algebraic structure of the transmitter can be obtained.

Requirement 2 *All trajectories of the transmitter equations must remain bounded for $t > 0$.*

A sufficient condition for which all trajectories of (6) remain bounded can be determined by defining a family of ellipsoids

$$V(\mathbf{x}) = \frac{1}{2} (\mathbf{x} - \mathbf{c})^T P (\mathbf{x} - \mathbf{c}) = k , \quad (7)$$

where P is a symmetric $N \times N$ positive definite matrix, \mathbf{c} is a vector which defines the center of the ellipsoids, and k is a positive scalar. As we show below, for k sufficiently large $V(\mathbf{x})$ will determine a trapping region for the N -dimensional flow.

If we restrict PA_1 to be skew-symmetric, then $\dot{V}(\mathbf{x})$ can be written in the form

$$\begin{aligned} \dot{V}(\mathbf{x}) &= (\mathbf{x} - \mathbf{l})^T \frac{(PA_0 + A_0^T P)}{2} (\mathbf{x} - \mathbf{l}) - \\ & \mathbf{l}^T \frac{(PA_0 + A_0^T P)}{2} \mathbf{l} + \\ & \mathbf{x}^T [(P\mathbf{a}^0 - 2A_1^T P\mathbf{c})x_1 + P\mathbf{s}^0 x_1^2] - \\ & \mathbf{c}^T (P\mathbf{a}^0 x_1 + P\mathbf{s}^0 x_1^2) , \end{aligned}$$

where the vector \mathbf{l} is given by

$$\mathbf{l} = (PA_0 + A_0^T P)^{-1} A_0^T P \mathbf{c} .$$

Sufficient conditions for $\dot{V} = 0$ to define an ellipsoid in state space are given below.

- $PA_1 = -A_1^T P$
- $(PA_0 + A_0^T P)$ is negative definite
- $\mathbf{s}^0 = \mathbf{0}$
- $\mathbf{a}^0 = -2A_1 \mathbf{c}$

Note that the first condition is the skew-symmetry restriction on PA_1 . The second condition can be satisfied by choosing a stable matrix A_0 such that $(PA_0 + A_0^T P)$ is negative definite. Note that the first two conditions are consistent with the self-synchronization conditions. The third condition excludes the quadratic drive term, $x_1^2(t)$, from the transmitter/receiver equations and reduces the number of free parameters which correspond to nonlinear terms to only $(N-1)(N-2)/2$. The fourth condition uniquely determines \mathbf{a}^0 in terms of A_1 and \mathbf{c} .

If these conditions are satisfied, then $\dot{V} = 0$ reduces to

$$\frac{(\mathbf{x} - \mathbf{l})^T (PA_0 + A_0^T P) (\mathbf{x} - \mathbf{l})}{\mathbf{l}^T (PA_0 + A_0^T P) \mathbf{l}} = 1 . \quad (8)$$

Because $(PA_0 + A_0^T P)$ is restricted to be negative definite, Eq. (8) defines an ellipsoid in state space. Since $\dot{V} < 0$ for all \mathbf{x} outside of the ellipsoid (8), any ellipsoid from the family (7) which contains (8) will suffice as a trapping region for the N -dimensional flow.

It is also important to recognize that if $\text{tr}(A_1) = 0$, then the transmitter equations will have a constant divergence. Specifically, the divergence of the vector field corresponding to (6) is given by

$$\nabla \cdot \dot{\mathbf{x}} = \text{tr}(A) + 2x_1 \text{tr}(A_1) .$$

Thus, if $\text{tr}(A_1) = 0$, then the system (6) will have a constant divergence. Note also that if $\text{tr}(A) < 0$, in

addition to $\text{tr}(A_1) = 0$, then the system (6) is dissipative with a constant negative divergence. Recall that a constant negative divergence implies that volumes in state space will go to zero exponentially fast at every point in R^N . This property ensures a rapid convergence of trajectories to a set of points having zero volume in state space. This property also has practical significance, and thus, we add a constant negative divergence requirement.

Requirement 3 *The transmitter equations must have a constant negative divergence.*

As discussed above, this requirement is satisfied if

- $\text{tr}(A_1) = 0$
- $\text{tr}(A) < 0$.

2.3. Summary of Self-Synchronization and Global Stability Results

Sufficient conditions on the algebraic structure of an N -dimensional nonlinear system which ensure that Requirements 1 through 3 are satisfied have been determined. Specifically, no nonlinearities in the drive equation are allowed and all remaining nonlinearities consist of cross product terms which include the drive variable. Thus, the transmitter can be conveniently expressed as

$$\dot{\mathbf{x}} = (A + 2A_1x_1)\mathbf{x} , \quad (9)$$

and the self-synchronizing receiver can be expressed as

$$\dot{\mathbf{x}}_r = (A_0 + 2A_1x_1)\mathbf{x}_r + \mathbf{a}^0x_1 . \quad (10)$$

Moreover, if the conditions

1. $RA_1 = -A_1^T R$, for some $N \times N$ positive definite matrix R
2. $(RA_0 + A_0^T R)$ is negative definite
3. $PA_1 = -A_1^T P$, for some $N \times N$ positive definite matrix P
4. $(PA_0 + A_0^T P)$ is negative definite
5. $\mathbf{a}^0 = -2A_1\mathbf{c}$
6. $\text{tr}(A_1) = 0$
7. $\text{tr}(A) < 0$

are satisfied, then the transmitter equations are dissipative and globally stable and the receiver system will possess the global self-synchronization property.

It is also important to recognize that if we choose $P = cR$, where c is a positive scalar, then conditions 1 and 3 and conditions 2 and 4 are equivalent. Furthermore, if we choose $R = \text{diag}(p, 1, \dots, 1)$, where p is a positive scalar, then condition 1 implies

that A_1 is skew-symmetric and condition 2 implies that A_0 is stable. In this case, conditions 6 and 7 will be automatically satisfied. In light of these simplifications, the following synthesis procedure is suggested.

Synthesis Procedure

1. Choose $R = \text{diag}(p, 1, \dots, 1)$, $p > 0$, and set $P = cR$, $c > 0$
2. Choose A_1 to be skew-symmetric, where the first row and column of A_1 is the zero vector
3. Choose any stable A_0 such that $(RA_0 + A_0^T R)$ is negative definite
4. Choose the vector \mathbf{c} arbitrarily and set $\mathbf{a}^0 = -2A_1\mathbf{c}$
5. With $A = A_0 + \mathbf{a}^0\mathbf{e}_1^T$, the transmitter and receiver equations are given by (9) and (10), respectively.

Another important issue concerns the stability of the fixed points. Specifically, we need to ensure that all of the fixed points of the transmitter equations are unstable so that non-trivial motion will occur. So far we have not determined any conditions for the fixed points to be unstable. Linear stability analysis of the transmitter equations (9) will help on this issue.

2.4. Linear Stability Analysis

Linearizing the vector field of (9) about the point \mathbf{x}_0 we obtain

$$\dot{\mathbf{x}} \simeq (A + 2A_1x_{10})\mathbf{x}_0 + J(\mathbf{x}_0)(\mathbf{x} - \mathbf{x}_0) , \quad (11)$$

where the Jacobian matrix, $J(\mathbf{x}_0)$, is given by

$$J(\mathbf{x}_0) = A + 2A_1(x_{10}I + \mathbf{x}_0\mathbf{e}_1^T) . \quad (12)$$

In many cases an analytical determination of the fixed points may not be possible. However, Eq. (11) provides a useful approach for determining the fixed points numerically. Specifically, the fixed points of (9) can be determined numerically by the Newton-Raphson iteration,

$$\mathbf{x}_0^{n+1} = \mathbf{x}_0^n - J(\mathbf{x}_0)^{-1}(A + 2A_1x_{10})\mathbf{x}_0 . \quad (13)$$

In practice, convergence to the fixed points is usually rapid. However, a large number of initial conditions should be tested in order to ensure that all of the fixed points have been found. Once the fixed points have been found, their stability is determined from the eigenvalues of $J(\mathbf{x}_0)$. For example, the origin of (9) is always a fixed point, and from (12) we observe that the origin's stability is determined by the eigenvalues of A . This provides a simple condition on the eigenvalues of A in order

to ensure that the origin is unstable. Specifically, the origin of the transmitter equations (9) is unstable if and only if A is an unstable matrix.

If any of the remaining fixed points are stable, we must adjust the free parameters in the transmitter equations and observe if chaotic motion occurs. Fortunately, there is a simple way to vary the transmitter parameters without violating any of self-synchronization and global stability conditions. Specifically, the Jacobian matrix (12) can be written in the form

$$J(\mathbf{x}_0) = A_0 + \mathbf{a}^0 \mathbf{e}_1^T + 2A_1(x_{10}I + \mathbf{x}_0 \mathbf{e}_1^T) .$$

Inspection of $J(\mathbf{x}_0)$ suggests that by fixing A_0 and A_1 the eigenvalues of $J(\mathbf{x}_0)$ can be affected by varying \mathbf{a}^0 . Since $\mathbf{a}^0 = -2A_1 \mathbf{c}$, we can adjust \mathbf{a}^0 by varying the \mathbf{c} vector. In typical cases, we have observed numerically that by increasing the magnitude of \mathbf{c} all of the fixed points eventually become unstable. Since the trajectories are bounded, either limit cycles or chaotic motion will result. Furthermore, invariant tori are not possible, because of the constant negative divergence requirement. Using specific examples, we will demonstrate this behavior numerically in the next section.

3. SYNTHESIS EXAMPLES WITH NUMERICAL EXPERIMENTS

As a first example, we will utilize the synthesis procedure to obtain the Lorenz equations. This example also shows that the Lorenz system is only one member of a class of three-dimensional chaotic systems which possess the self-synchronizing property. Subsequent examples will consider the synthesis of higher dimensional systems.

3.1. Synthesizing the Lorenz System

To begin, we must choose the state space dimension N , define $R = \text{diag}(p, 1, \dots, 1)$, $p > 0$, and select an appropriate A_1 . Recall that the elements of A_1 correspond to the nonlinear terms in the transmitter equations. There are exactly $(N-1)(N-2)/2$ independent free parameters in A_1 . Thus, for a three-dimensional system there is only one free parameter.

To illustrate the method, suppose we choose $N = 3$, $R = \text{diag}(1/\sigma, 1, 1)$, and A_1 as

$$A_1 = \begin{bmatrix} 0 & 0 & 0 \\ 0 & 0 & -1/2 \\ 0 & 1/2 & 0 \end{bmatrix} .$$

Note that A_1 is skew-symmetric and that $RA_1 = -A_1^T R$. Next we must choose a stable matrix A_0 such that $(RA_0 + A_0^T R)$ is negative definite. A simple way to ensure that A_0 is stable is to choose

A_0 to be upper triangular with negative coefficients on the main diagonal. For example, suppose we choose

$$A_0 = \begin{bmatrix} -\sigma & \sigma & 0 \\ 0 & -1 & 0 \\ 0 & 0 & -b \end{bmatrix} ,$$

where $\sigma, b > 0$. Clearly A_0 is a stable matrix, and it is straightforward to verify that $(RA_0 + A_0^T R)$ is negative definite. Next, we must choose the \mathbf{c} vector. Recall that \mathbf{c} determines the center of the ellipsoidal trapping region in state space. For example, suppose we choose

$$\mathbf{c} = r \begin{bmatrix} 0 \\ 0 \\ 1 \end{bmatrix} .$$

At this point, we have enough information to fully specify the transmitter equations. The vector $\mathbf{a}^0 = -2A_1 \mathbf{c}$ is given by

$$\mathbf{a}^0 = \begin{bmatrix} 0 \\ r \\ 0 \end{bmatrix} .$$

The linear coefficient matrix $A = A_0 + \mathbf{a}^0 \mathbf{e}_1^T$ is given by

$$A = \begin{bmatrix} -\sigma & \sigma & 0 \\ r & -1 & 0 \\ 0 & 0 & -b \end{bmatrix} .$$

When the transmitter equations are written in terms of a set of first-order differential equations we obtain

$$\begin{aligned} \dot{x}_1 &= \sigma(x_2 - x_1) \\ \dot{x}_2 &= rx_1 - x_2 - x_1x_3 \\ \dot{x}_3 &= x_1x_2 - bx_3 , \end{aligned}$$

which we recognize as the well known Lorenz system [Lorenz, 1963].

3.2. Synthesizing a Four-Dimensional Chaotic System

In four dimensions, the matrix A_1 contains three free parameters. These parameters may be chosen arbitrarily. Suppose, for example, that we choose A_1 as

$$A_1 = \begin{bmatrix} 0 & 0 & 0 & 0 \\ 0 & 0 & -1/2 & -1/2 \\ 0 & 1/2 & 0 & 1/2 \\ 0 & 1/2 & -1/2 & 0 \end{bmatrix} .$$

By analogy with the Lorenz example, suppose that we choose A_0 as

$$A_0 = \begin{bmatrix} -16 & 16 & 0 & 0 \\ 0 & -1 & 0 & 0 \\ 0 & 0 & -4 & 0 \\ 0 & 0 & 0 & -1 \end{bmatrix}.$$

These choices satisfy the synthesis conditions for $R = \text{diag}(1/16, 1, 1, 1)$. Finally, we choose the \mathbf{c} vector as

$$\mathbf{c} = r \begin{bmatrix} 0 \\ 0 \\ .25 \\ 1 \end{bmatrix},$$

where r is treated as a bifurcation parameter. The vector $\mathbf{a}^0 = -2A_1\mathbf{c}$ is given by

$$\mathbf{a}^0 = r \begin{bmatrix} 0 \\ 1.25 \\ -1 \\ .25 \end{bmatrix},$$

and the linear coefficient matrix $A = A_0 + \mathbf{a}^0\mathbf{e}_1^T$ is given by

$$A = \begin{bmatrix} -\sigma & \sigma & 0 & 0 \\ 1.25r & -1 & 0 & 0 \\ -r & 0 & -b & 0 \\ .25r & 0 & 0 & -1 \end{bmatrix}.$$

When the transmitter equations are written in terms of a set of first-order differential equations we obtain

$$\begin{aligned} \dot{x}_1 &= 16(x_2 - x_1) \\ \dot{x}_2 &= 1.25rx_1 - x_2 - x_1x_3 - x_1x_4 \\ \dot{x}_3 &= -rx_1 - 4x_3 + x_1x_2 + x_1x_4 \\ \dot{x}_4 &= .25rx_1 - x_4 + x_1x_2 - x_1x_3. \end{aligned}$$

As an illustration of the nonlinear dynamical behavior of the transmitter equations, consider Fig. 2 which shows the computed Lyapunov exponents as r is varied over the range $20 < r < 100$. The QR decomposition method of Eckmann & Ruelle [1985] was used to compute the exponents numerically. Note that the onset of chaotic behavior occurs near $r = 42$, as evidenced by the existence of a positive Lyapunov exponent. Note also that two negative exponents are apparent as well as the zero exponent. For comparison purposes, the computed Lyapunov exponents for the Lorenz system are also shown (dashed lines).

Figure 3 shows the computed Lyapunov dimension as r is varied over the same range. The Lyapunov dimension, D_L , is defined by

$$D_L = k + \frac{\lambda_1 + \dots + \lambda_k}{|\lambda_{k+1}|},$$

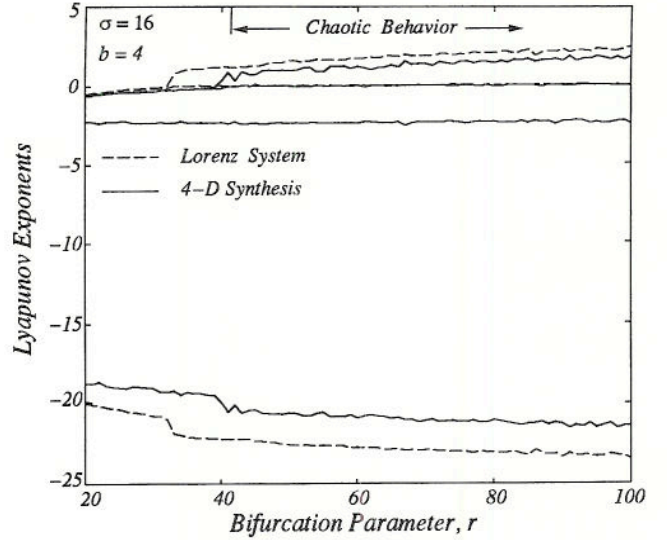

Figure 2: Lyapunov Exponents for a 4-Dimensional Chaotic System.

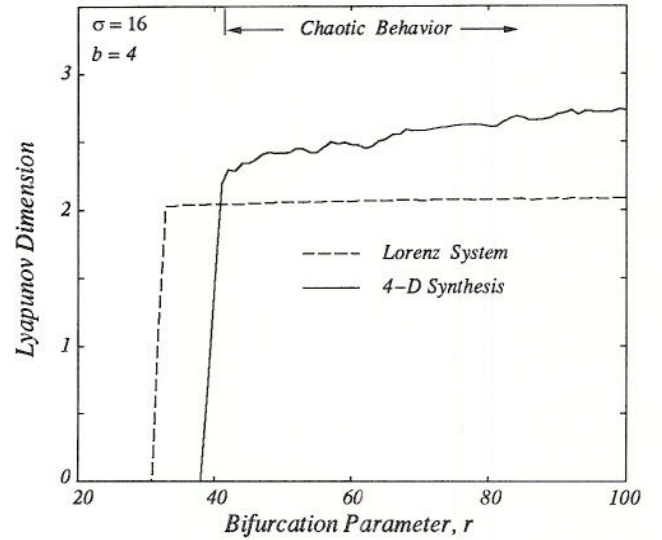

Figure 3: Lyapunov Dimension for a 4-Dimensional Chaotic System.

where $\lambda_1, \dots, \lambda_N$ are the Lyapunov exponents of a chaotic system and where $k = \max\{i : \lambda_1 + \dots + \lambda_i > 0\}$. The Lyapunov dimension provides a useful and meaningful measure of the fractional dimension of a chaotic attractor. Note that the Lyapunov dimension increases significantly as r increases. This is in contrast to the Lorenz system, where the attractor dimension is approximately constant at a value near 2.06.

Figure 4 shows various projections of the chaotic attractor corresponding to $r = 60$. Note that the (x_1, x_2) projection is qualitatively similar to the Lorenz attractor. The (x_1, x_3) projection is also similar to the Lorenz attractor except that one of the "wings" is twisted. The remaining projections illustrate the complicated topology of the chaotic

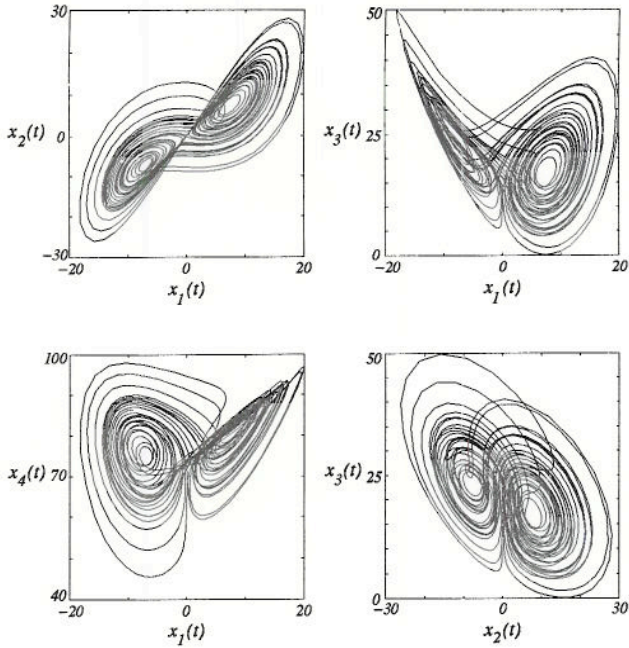

Figure 4: Chaotic Attractor Projections for a 4-Dimensional Chaotic System ($r = 60$).

attractor.

The self-synchronizing receiver equations are given by

$$\begin{aligned}\dot{x}_{1r} &= 16(x_{2r} - x_{1r}) \\ \dot{x}_{2r} &= 1.25rx_1(t) - x_{2r} - x_1(t)x_{3r} - x_1(t)x_{4r} \\ \dot{x}_{3r} &= -rx_1(t) - 4x_{3r} + x_1(t)x_{2r} + x_1(t)x_{4r} \\ \dot{x}_{4r} &= .25rx_1(t) - x_{4r} + x_1(t)x_{2r} - x_1(t)x_{3r} .\end{aligned}$$

Figure 5 illustrates the exponentially fast synchronization between the transmitter and receiver systems. The curve measures the distance in state space between the transmitter and receiver trajectory, when the receiver is initialized from the zero state. Synchronization is rapid and is maintained indefinitely.

3.3. Synthesizing an Arbitrary Five-Dimensional Chaotic System

To further emphasize the simplicity and generality of the synthesis procedure, we consider the design of a 5-dimensional chaotic system. Specifically, consider the matrix A_1 given by

$$A_1 = \begin{bmatrix} 0 & 0 & 0 & 0 & 0 \\ 0 & 0 & -.56 & -.91 & .36 \\ 0 & .56 & 0 & .36 & .87 \\ 0 & .91 & -.36 & 0 & -.23 \\ 0 & -.36 & -.87 & .23 & 0 \end{bmatrix} .$$

In this case, the six free parameters of A_1 were selected at random from the normal distribution with zero mean and unit variance. Next, consider

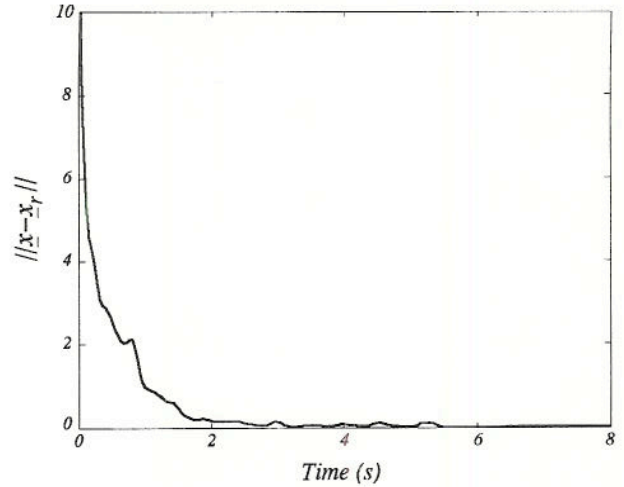

Figure 5: Self-Synchronization in a 4-Dimensional Chaotic System.

the stable matrix A_0 given by

$$A_0 = \begin{bmatrix} -16 & 16 & 3.66 & 0 & 0 \\ 0 & -1 & .06 & -.80 & 0 \\ 0 & 0 & -4 & -1.07 & 1.55 \\ 0 & 0 & 0 & -1 & .38 \\ 0 & 0 & 0 & 0 & -1 \end{bmatrix} .$$

Note that randomly selected elements have been placed above the main diagonal of A_0 . It is straightforward to verify that these choices satisfy the synthesis conditions for $R = \text{diag}(1/16, 1, 1, 1, 1)$. Finally, we choose the \mathbf{c} vector as

$$\mathbf{c} = r \begin{bmatrix} .00 \\ .00 \\ .04 \\ .58 \\ -.82 \end{bmatrix} ,$$

where r is treated as a bifurcation parameter. The vector $\mathbf{a}^0 = -2A_1\mathbf{c}$ is given by

$$\mathbf{a}^0 = r \begin{bmatrix} .00 \\ 1.68 \\ 1.00 \\ -.35 \\ -.20 \end{bmatrix} ,$$

and the linear coefficient matrix $A = A_0 + \mathbf{a}^0\mathbf{e}_1^T$ is given by

$$A = \begin{bmatrix} -16 & 16 & 3.66 & 0 & 0 \\ 1.68r & -1 & .06 & -.08 & 0 \\ 1.00r & 0 & -4 & -1.07 & 1.55 \\ -.35r & 0 & 0 & -1 & .38 \\ -.20r & 0 & 0 & 0 & -1 \end{bmatrix} .$$

The transmitter equations are fully determined, and are of the form $\dot{\mathbf{x}} = (A + 2A_1x_1)\mathbf{x}$.

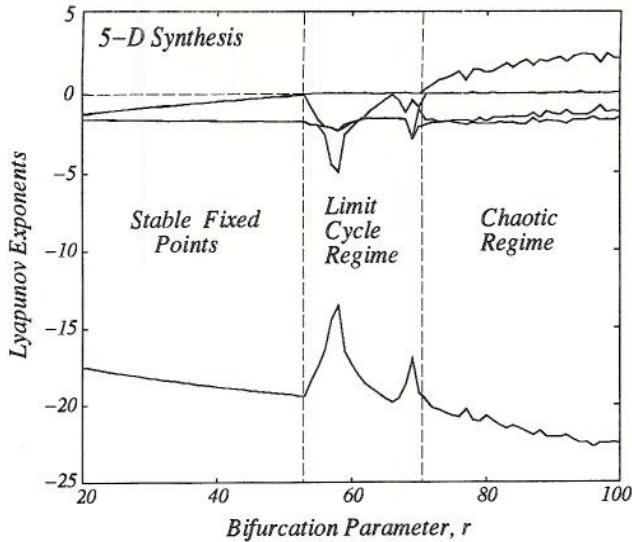

Figure 6: *Lyapunov Exponents for a 5-Dimensional Chaotic System.*

As an illustration of the nonlinear dynamical behavior exhibited by the transmitter equations, consider Fig. 6 which shows the computed Lyapunov exponents as r is varied over the range $20 < r < 100$. As r increases, all of the fixed points eventually lose stability and the motion is confined to stable limit cycles. These limit cycles lose stability near $r = 70$ and a chaotic attractor appears, as evidenced by the existence of a positive Lyapunov exponent. Note also that three negative exponents are evident in the chaotic regime.

Figure 7 shows the Lyapunov dimension as r is varied over the same range. This figure clearly shows the presence of the limit cycle regime ($D_L = 1$). After a sequence of bifurcations takes place, the Lyapunov dimension increases sharply as r enters the chaotic regime.

Figure 8 shows various projections of the chaotic attractor corresponding to $r = 90$. These projections clearly illustrate the extremely complicated topology of the chaotic attractor.

Figure 9 demonstrates that synchronization takes place between the transmitter and receiver systems. The curve measures the distance in state space between the transmitter and receiver trajectory, when the receiver is initialized from the zero state. Synchronization is rapid and is maintained indefinitely.

It should be emphasized that it is also straightforward to synthesize significantly higher dimensional systems. The relatively low-order systems discussed in this section were chosen to illustrate the synthesis approach, rather than to suggest limitations.

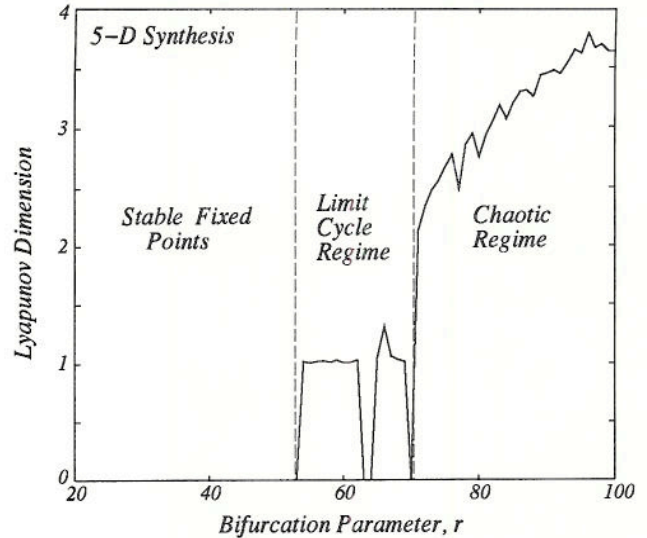

Figure 7: *Lyapunov Dimension for a 5-Dimensional Chaotic System.*

4. CONCLUSIONS

In this paper, we have developed a systematic approach for synthesizing a class of N -dimensional dissipative chaotic systems which possess the self-synchronization property. The ability to synthesize new chaotic systems further enhances the usefulness of synchronized chaotic systems for communications and signal processing. Exploring the wealth of nonlinear dynamical behavior exhibited by this class of systems is an exciting topic for future research. There is also considerable potential for designing and implementing new chaotic circuits which could form the basis of a secure communication system.

We note that it would also be an interesting future experiment to explore the possibility of utilizing our synthesis procedure to obtain a set of transmitter equations which exhibit multiple positive Lyapunov exponents. If this were possible, then it follows that hyperchaotic self-synchronization can be achieved when the receiver is driven by only a single transmitter component.

ACKNOWLEDGEMENTS

The author thanks A. V. Oppenheim, S. H. Strogatz, and A. S. Willsky for valuable discussions during various stages of this work. This work was sponsored in part by AFOSR under Grant Number AFOSR-91-0034-A, in part by a subcontract from Lockheed Sanders, Inc., under ONR Contract Number N00014-91-C-0125, and in part by the ONR under Grant Number N00014-93-1-0686. Support from the M.I.T. Lincoln Laboratory Staff Associate Program is also gratefully acknowledged.

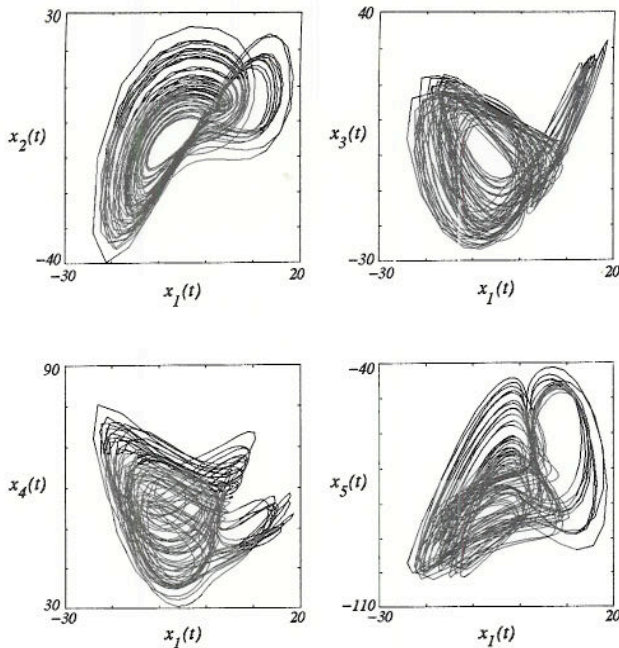

Figure 8: Chaotic Attractor Projections for a 5-Dimensional Chaotic System ($r = 90$).

REFERENCES

- [1] Carroll, T. L., & Pecora, L. M. [1991] "Synchronizing chaotic circuits," *IEEE Trans. Circuits Systems* **38**, 453-456.
- [2] Cuomo, K. M. & Oppenheim, A. V. [1992] "Synchronized chaotic circuits and systems for communications," *MIT Research Laboratory of Electronics TR No. 575*.
- [3] Cuomo, K. M. & Oppenheim, A. V. [1993] "Chaotic signals and systems for communications," in *Proc. 1993 IEEE ICASSP III*, 137-140.
- [4] Cuomo, K. M. & Oppenheim, A. V. [1993] "Circuit implementation of synchronized chaos with applications to communications," *Phys. Rev. Lett.* **71**, 65-68.
- [5] Eckmann, J. P. & Ruelle, D. [1985] "Ergodic theory of chaos and strange attractors," *Rev. Modern Phys.* **57**, 617-656.
- [6] He, R. & Vaidya, P. G. [1992] "Analysis and synthesis of synchronous periodic and chaotic systems," *Phys. Rev.* **A46**, 7387-7392.
- [7] Kocarev, Lj., Halle, K. S., Eckert, K. & Chua, L. O. [1992] "Experimental demonstration of secure communications via chaotic synchronization," *Int. J. Bifurcation and Chaos* **2**(3), 709-713.
- [8] Lorenz, E. N. [1963] "Deterministic nonperiodic flow," *J. Atmospheric Sciences* **20**, 130-141.
- [9] Oppenheim, A. V., Wornell, G. W., Isabelle, S. H. & Cuomo K. M. [1992] "Signal processing in the context of chaotic signals," in *Proc. 1992 IEEE ICASSP IV*, 117-120.
- [10] Parlitz, U., Chua, L. O., Kocarev, Lj., Halle, K. S., & Shang, A. [1992] "Transmission of digital signals by chaotic synchronization," *Int. J. Bifurcation and Chaos* **2**(4), 973-977.

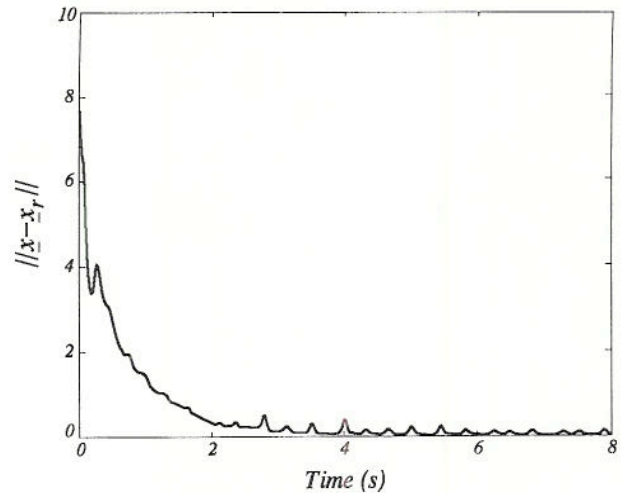

Figure 9: Self-Synchronization in a 5-Dimensional Chaotic System.

- [11] Pecora, L. M. & Carroll, T. L. [1990] "Synchronization in chaotic systems," *Phys. Rev. Lett.* **64**, 821-823.
- [12] Pecora, L. M. & Carroll, T. L. [1991] "Driving systems with chaotic signals," *Phys. Rev.* **A44**, 2374-2383.